

ONU Integrated T1 Master Device Installation Manual

1. Product Overview

Hangzhou Prevail 1000Base-T1 product series leverages the widely adopted 1000Base-T1 technology from automotive networking, offering controlled costs and stable chip set performance. By utilizing existing coaxial infrastructure in cable networks, it effectively addresses the challenges of fiber-to-the-home deployment, enables bidirectional Gigabit IP transmission, and helps increase the market penetration of Gigabit broadband.

ONU Integrated T1 Master Device, model WLT-GP-M1, is an integrated ONU product with Gigabit coaxial transmission capability. It provides standard PON-based fiber access functionality, while also offering a practical interface based on Gigabit coaxial transmission technology.

Key Product Features:

- Provides one bidirectional Gigabit coaxial transmission ports with power feeding capability
- Provides one optical port with GPON/EPON auto-adaptation
- Provides one LAN port with 10/100/1000 Mbps auto-negotiation



**ONU Integrated T1 Master Device
WLT-GP-M1**

2. Interface and Indicator Description

Interface Functions Description

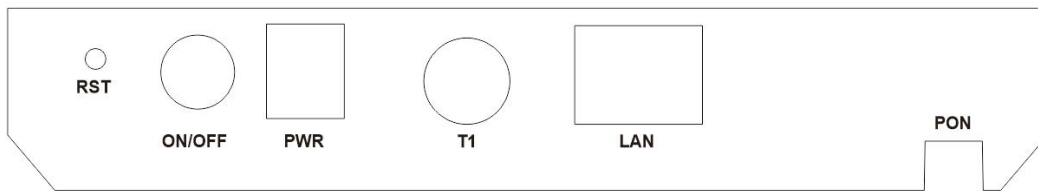

RST	The reset button of the device
ON/OFF	Power switch button (with lock)
PWR	DC 12V power input port (connecting power adapter)
PON	PON optical adapter port
LAN	LAN GE Ethernet port
T1	T1 GbE coaxial F-type port

Indicator Lights Description

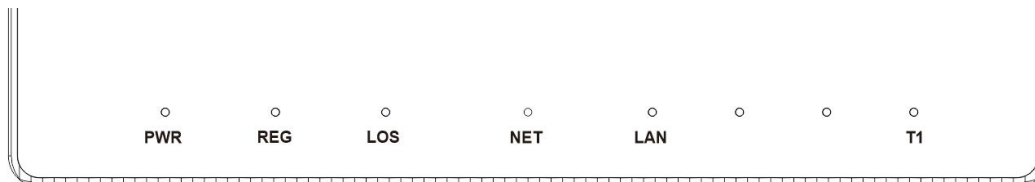

Identification	Status	Definition
PWR	ON	POWER ON
	OFF	POWER OFF
REG	ON	Optic Fiber access and successful registration
	Flashing	Optic Fiber access but unregistered
	OFF	Optic Fiber not connected
LOS	Slow Flashing	Receiving optical power is too low
	OFF	Receiving optical power is normal
NET	Flashing	WAN network connected and IP address obtained
	OFF	WAN not connected
LAN	ON	Ethernet interface is connected
	Flashing	Ethernet data is transmission
	OFF	Ethernet interface is not in use
T1	ON	GE Coaxial interface is connected
	Flashing	GE Coaxial data is transmission
	OFF	GE Coaxial interface is not in use

3. Application Scenario Example (Multi-Service Home Deployment)

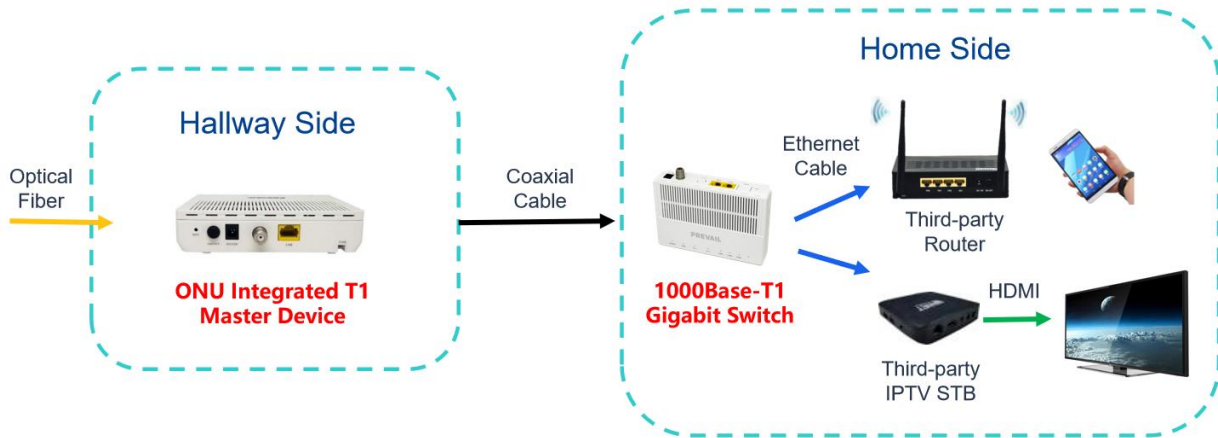

- In a fiber-to-the-building (FTTB) environment, existing coaxial cable resources are utilized.
- An ONU Integrated T1 Master Device is deployed on the hallway side to enable IP signal transmission and conversion between optical fiber and coaxial cables.
- On the user side it can be equipped with a 1000BASE-T1 Gigabit Switch to enable IP signal transmission and conversion between coaxial cables and Ethernet cables.
- This supports multi-service access (Gigabit broadband and IPTV), effectively addressing the challenges of cable operator FTTH deployment.

Connection Diagram for Power Feeding Mode:

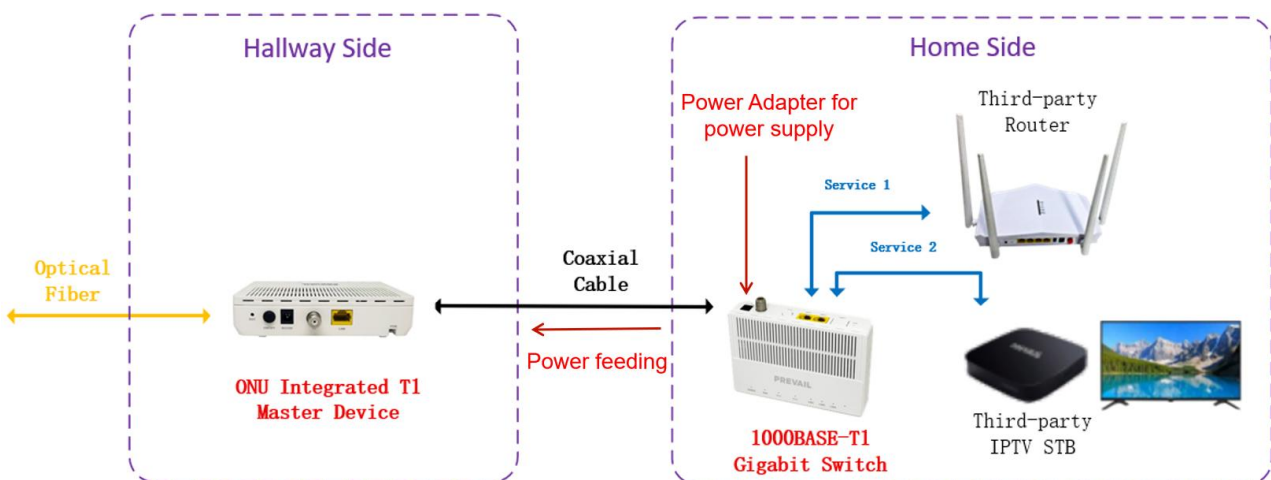

The detailed installation steps for power feeding mode are as follows:

Step 1	Check the quality of the coaxial cable								
	It is recommended to inspect the quality of the coaxial cable between the hallway and the subscriber side for any damage or aging.								
	Measure the resistance of the coaxial cable to determine whether it meets the requirements for using T1 devices. The detailed procedure is as follows:								
	Prepare a 75-ohm load, a through-type connector, and a multi-meter.								
	Tighten the 75-ohm load and the through-type connector on the hallway side, and connect one end of the coaxial cable.								
	On the home side, switch on the multi-meter, set it to resistance (Ω) range, and measure the resistance between the coaxial inner conductor and the shield using the probes.								
	By subtracting the 75-ohm termination value from the measured resistance, a parameter R is obtained to evaluate whether the coaxial cable is suitable for T1 device operation. See the table below for details:								
	<table border="1" data-bbox="296 837 1385 1016"> <thead> <tr> <th data-bbox="296 837 608 875">R</th> <th data-bbox="614 837 1385 875">Reference Guidelines for Home Installation</th> </tr> </thead> <tbody> <tr> <td data-bbox="296 884 608 922">$0 < R \leq 7.0 \Omega$</td> <td data-bbox="614 884 1385 922">T1 devices can be used, and power feeding is supported.</td> </tr> <tr> <td data-bbox="296 931 608 969">$7.0 \Omega < R \leq 13.0 \Omega$</td> <td data-bbox="614 931 1385 969">T1 devices can be used, but power feeding is not supported.</td> </tr> <tr> <td data-bbox="296 978 608 1016">$13.0 \Omega < R$</td> <td data-bbox="614 978 1385 1016">The coaxial cable is not suitable for T1 device operation.</td> </tr> </tbody> </table>	R	Reference Guidelines for Home Installation	$0 < R \leq 7.0 \Omega$	T1 devices can be used, and power feeding is supported.	$7.0 \Omega < R \leq 13.0 \Omega$	T1 devices can be used, but power feeding is not supported.	$13.0 \Omega < R$	The coaxial cable is not suitable for T1 device operation.
R	Reference Guidelines for Home Installation								
$0 < R \leq 7.0 \Omega$	T1 devices can be used, and power feeding is supported.								
$7.0 \Omega < R \leq 13.0 \Omega$	T1 devices can be used, but power feeding is not supported.								
$13.0 \Omega < R$	The coaxial cable is not suitable for T1 device operation.								
Step 2	Hallway Side Installation								
	Package contents: 1 × power adapter, 1 × ONU Integrated T1 Master Device.								
	Be sure to use the original power adapter. Using non-original power adapters may result in failure to start properly or service degradation.								
	Deploy one ONU Integrated T1 Master Device on the hallway side.								
	Take a photo of the label on the back of the ONU Integrated T1 Master Device, and record the ONU MAC address / GPON SN.								
	Connect the fiber to the optical port of the ONU Integrated T1 Master Device.								
	Connect coaxial cables to the T1 ports of the ONU Integrated T1 Master Device								
	Note: Do not forget to press the power button on the ONU Integrated T1 Master Device to enable proper reverse power feeding from the user side.								
Step 3	Home Side Installation								
	Install another 1000BASE-T1 Gigabit switch on the home side.								
	Connect the T1 coaxial port of the T1 Gigabit switch to the incoming coaxial cable.								
	To ensure proper performance and user experience, please use the original power adapter.								
	Use the original power adapter to connect the power port of the T1 Gigabit switch, and plug it into a power outlet.								
	At this stage, the user-side T1 switch and the hallway-side ONU Integrated T1 Master Device should both be able to start up via the power feeding system.								
	It can be observed that the T1 coaxial status indicator on the home-side T1 Gigabit switch turns green, indicating that the T1 Devices at both ends of the coaxial cable are successfully connected.								

	Contact the OLT/central office staff and report the previously recorded MAC address / GPON SN to verify whether the ONU Integrated T1 Master Device has been registered, activated online, and provisioned with services.
	Special note for service provisioning by central office personnel: the T1 switch is factory-configured with LAN1 set to VLAN 18 and LAN2 set to VLAN 17. The T1 port allows both VLAN 17 and VLAN 18 to pass through. Therefore, it is recommended that VLAN translation rules be configured via the OLT on the T1 port of the ONU Integrated T1 Master Device (the T1 port corresponds to LAN4). For example: convert the original broadband service VLAN 15 to VLAN 18, and convert the IPTV service VLAN 14 to VLAN 17.
Step 4	Home-Side Service Testing
	Connect an Ethernet cable to LAN1 of the home-side T1 Gigabit switch, and connect the WAN port of the router to the same cable.
	Use a mobile phone or computer to connect to the router, set the PPPoE credentials (username and password), and verify that the Gigabit broadband service is operating normally.
	Connect an Ethernet cable to LAN2 of the T1 Gigabit switch, and connect the IPTV set-top box to the same cable. Check whether the on-demand service is functioning properly.

4. Installation Precautions

1. Use the factory-supplied power adapter to power the T1 device. In power feeding mode, this requirement must be strictly followed.
2. The 1000BASE-T1 solution does not support networking via splitters.
3. When power feeding is provided via coaxial cable, the supply voltage to the hallway-side T1 device may be affected by the length and material of the coaxial cable. The typical operating voltage for mainstream devices should not be lower than 9.5V.
4. In non-power-feeding mode, the installation procedure is basically the same as in power feeding mode. The T1 switch and the ONU Integrated T1 Master Device should be powered separately using their own power adapters.