

ONU Integrated 4*T1 Ports Master Device Installation Manual

1. Product Overview

Hangzhou Prevail 1000Base-T1 product series leverages the widely adopted 1000Base-T1 technology from automotive networking, offering controlled costs and stable chip set performance. By utilizing existing coaxial infrastructure in cable networks, it effectively addresses the challenges of fiber-to-the-home deployment, enables bidirectional Gigabit IP transmission, and helps increase the market penetration of Gigabit broadband.

ONU Integrated 4*T1 Ports Master Device, model WLT-GP-M4J, is an integrated ONU product with Gigabit coaxial transmission capability. It provides standard PON-based fiber access functionality, while also offering practical interfaces based on Gigabit coaxial transmission technology.

Key Product Features:

- Provides four bidirectional Gigabit coaxial transmission ports
- Provides one optical port with GPON/EPON auto-adaptation



**ONU Integrated 4*T1 Ports Master Device
WLT-GP-M4J**

2. Interface and Indicator Description

Front Panel Description



Identification	Status	Definition
PWR (LED)	ON	POWER ON
	OFF	POWER OFF
REG (LED)	ON	Optic Fiber access and successful registration
	Flashing	Optic Fiber access but unregistered
	OFF	Optic Fiber not connected
LOS (LED)	Slow Flashing	Receiving optical power is too low
	OFF	When powered on, receiving optical power is normal
NET (LED)	ON (or flashing)	WAN network connected and IP address obtained
	OFF	WAN not connected
PWR	DC power input(+12VDC power adapter)	
PON	Optical fiber PON adapter connection port	
RST	Reset button, built-in touch switch	

Back Panel Description



T1-1~T1-4	Four 1000Base-T1 coaxial interfaces (1, 2, 3, 4 ports)
(LED1~LED4)	ON: T1 connection is successful Flashing: Data is transmission

3. Application Scenario Example (Multi-user Multi-Service Home Deployment)

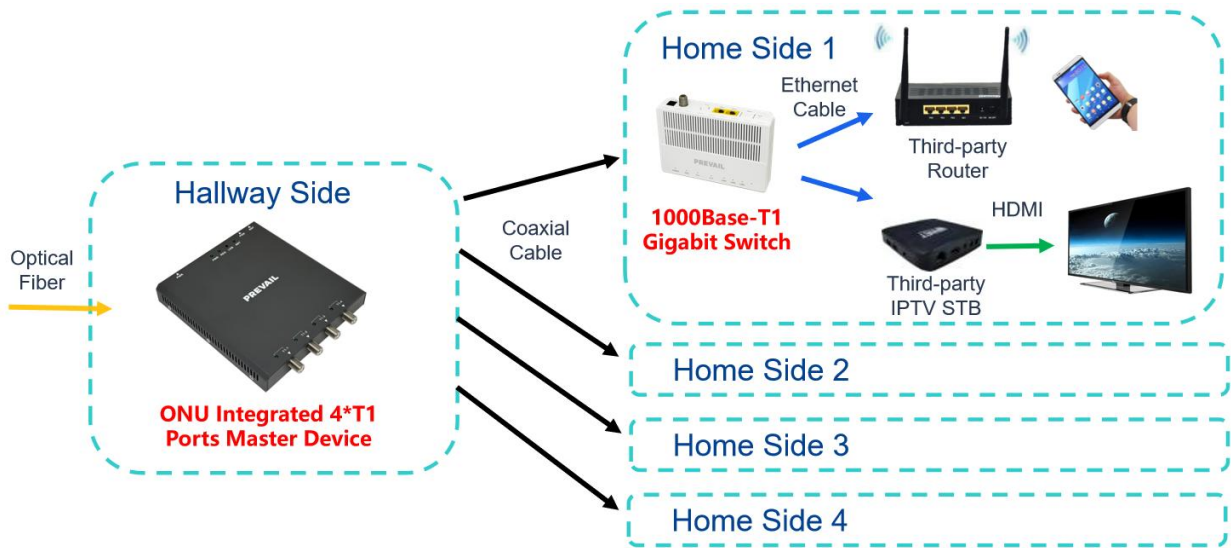

- In a fiber-to-the-building (FTTB) environment, existing coaxial cable resources are utilized.
- An ONU Integrated 4*T1 Ports Master Device is deployed on the hallway side to enable IP signal transmission and conversion between optical fiber and coaxial cables.
- On the user side, up to four users can each be equipped with a 1000BASE-T1 Gigabit Switch to enable IP signal transmission and conversion between coaxial cables and Ethernet cables.
- This supports multi-user, multi-service access (Gigabit broadband and IPTV), effectively addressing the challenges of cable operator FTTH deployment.

The detailed installation steps are as follows:

Step 1	Check the quality of the coaxial cable								
	It is recommended to inspect the quality of the coaxial cable between the hallway and the subscriber side for any damage or aging.								
	Measure the resistance of the coaxial cable to determine whether it meets the requirements for using T1 devices. The detailed procedure is as follows:								
	Prepare a 75-ohm load, a through-type connector, and a multi-meter.								
	Tighten the 75-ohm load and the through-type connector on the hallway side, and connect one end of the coaxial cable.								
	On the home side, switch on the multi-meter, set it to resistance (Ω) range, and measure the resistance between the coaxial inner conductor and the shield using the probes.								
	By subtracting the 75-ohm termination value from the measured resistance, a parameter R is obtained to evaluate whether the coaxial cable is suitable for T1 device operation. See the table below for details:								
	<table border="1"> <thead> <tr> <th>R</th> <th>Reference Guidelines for Home Installation</th> </tr> </thead> <tbody> <tr> <td>$0 < R \leq 7.0 \Omega$</td> <td>T1 devices can be used, and power feeding is supported.</td> </tr> <tr> <td>$7.0 \Omega < R \leq 13.0 \Omega$</td> <td>T1 devices can be used, but power feeding is not supported.</td> </tr> <tr> <td>$13.0 \Omega < R$</td> <td>The coaxial cable is not suitable for T1 device operation.</td> </tr> </tbody> </table>	R	Reference Guidelines for Home Installation	$0 < R \leq 7.0 \Omega$	T1 devices can be used, and power feeding is supported.	$7.0 \Omega < R \leq 13.0 \Omega$	T1 devices can be used, but power feeding is not supported.	$13.0 \Omega < R$	The coaxial cable is not suitable for T1 device operation.
R	Reference Guidelines for Home Installation								
$0 < R \leq 7.0 \Omega$	T1 devices can be used, and power feeding is supported.								
$7.0 \Omega < R \leq 13.0 \Omega$	T1 devices can be used, but power feeding is not supported.								
$13.0 \Omega < R$	The coaxial cable is not suitable for T1 device operation.								

Step 2	Hallway Side Installation
	Package contents: 1 × power adapter, 1 × ONU Integrated 4*T1 Ports Master Device.
	Be sure to use the original power adapter. Using non-original power adapters may result in failure to start properly or service degradation.
	Deploy one ONU Integrated 4*T1 Ports Master Device on the hallway side.
	Connect the fiber to the optical port of the ONU Integrated 4*T1 Ports Master Device.
	Connect coaxial cables to the T1 ports of the ONU Integrated 4*T1 Ports Master Device, with each port supporting up to one household (maximum four households).
	Use the factory-supplied power adapter.
	Plug it into a power outlet.
	Report the MAC address / GPON SN from the label on the rear of the ONU Integrated 4*T1 Ports Master Device to the central office for registration and service provisioning.
	<p>Special note for service provisioning by central office personnel: the home-side T1 switch is factory-configured with LAN1 set to VLAN 18 and LAN2 set to VLAN 17.</p> <p>The T1 port allows both VLAN 17 and VLAN 18 to pass through. Therefore, it is recommended that VLAN translation rules be configured on the T1 port of the ONU Integrated 4*T1 Ports Master Device via the OLT, for example: convert the original broadband service VLAN 15 to VLAN 18, and convert the IPTV service VLAN 1323 to VLAN 17.</p>
	A steady REG LED indicates successful registration. A flashing NET LED indicates that the external network is connected.
Step 3	Home Side Installation
	Install another 1000BASE-T1 Gigabit switch on the home side.
	Connect the T1 coaxial port of the T1 Gigabit switch to the incoming coaxial cable.
	To ensure proper performance and user experience, please use the original power adapter.
	Use the original power adapter to connect the power port of the T1 Gigabit switch, and plug it into a power outlet.
	It can be observed that the T1 coaxial status indicator on the home-side T1 Gigabit switch turns green, indicating that the T1 Devices at both ends of the coaxial cable are successfully connected.
Step 4	Home-Side Service Testing
	Connect an Ethernet cable to LAN1 of the home-side T1 Gigabit switch, and connect the WAN port of the router to the same cable.
	Use a mobile phone or computer to connect to the router, set the PPPoE credentials (username and password), and verify that the Gigabit broadband service is operating normally.
	Connect an Ethernet cable to LAN2 of the T1 Gigabit switch, and connect the IPTV set-top box to the same cable. Check whether the on-demand service is functioning properly.

4. Installation Precautions

1. Be sure to use the factory-supplied power adapter to power the T1 devices.
2. The 1000BASE-T1 solution does not support the use of splitters.
3. The current ONU Integrated 4*T1 Ports Master Device does not support power feeding.